

Kunden-Pos.-Nr.:
 Bestell-Datum: 02.03.2011
 Bestellnummer: Blitzangebot 2011-03-02
 Menge: 1

Nummer:
 Positionsr.: 1800
 Datum: 02.03.2011
 Seite: 1 / 4

Ama-Drainer A 522 ND/11

Versions-Nr.: 1

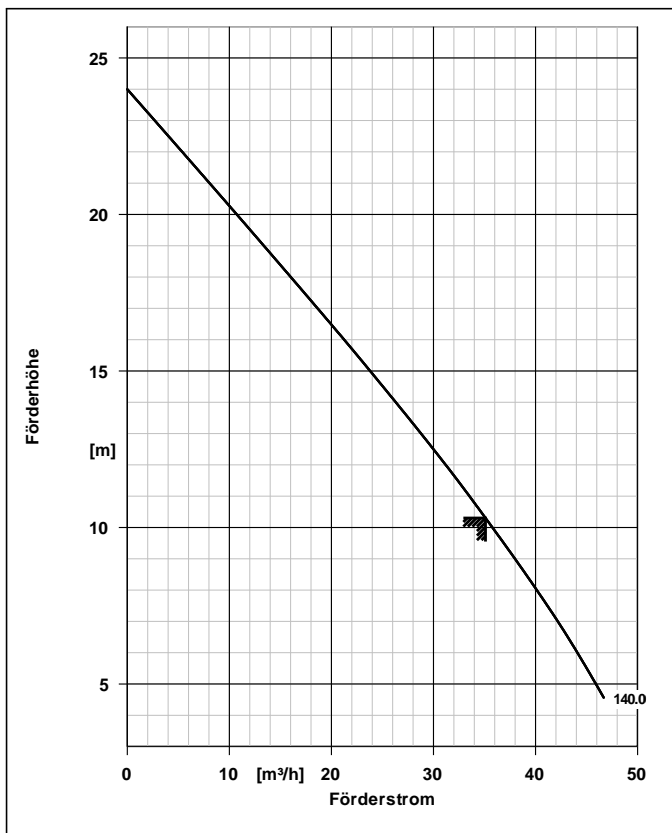

Werkstoffe A	
Werkstoffausführung	Standardausführung für Schmutzwasser, auch mit Feststoffanteilen.
Hinweise	
Pumpengehäuse (101)	Grauguss JL1040
Saugdeckel (162)	Grauguss JL1040
Pumpenstützfuss (182)	Polyethylen (HDPE)
Welle (210)	Chrom-Stahl 1.4021+QT800
Lauftrad (230)	POLYAMID (PA)
Betriebsdaten	
Fördermedium	Wasser sauberes Wasser Chemisch und mechanisch die Werkstoffe nicht angreifend
Temperatur Fördermedium	20,0 °C
Fördermenge	35,10 m³/h
Förderhöhe	10,30 m
Ausführung	Einzelpumpe 1 x 100 %
Antrieb, Zubehör	
Frequenz	50 Hz
Betriebsspannung	400 V
elektr. Anschlussleistung P1	2,90 kW
Motorbemessungsleist. P2	2,20 kW
Motornennstrom	4,8 A
Leitungslänge	10,00 m
Aufstellteile	
Lieferumfang	Pumpe ohne Aufstellteile

Ausführung	
Ausführung	Blockbauweise, Tauchmotor
Max. Mediumtemperatur	50,0 °C
Druckstutzen Nennweite	G 2
90°-Winkelstück mit Innengewinde G2 im Lieferumfang	
Wellendichtung	Einfachwirkende GLRD
Freier Durchgang	11,0 mm

Kunden-Pos.-Nr.:
 Bestell-Datum: 02.03.2011
 Bestellnummer: Blitzangebot 2011-03-02
 Menge: 1

Nummer:
 Positionsnr.: 1800
 Datum: 02.03.2011
 Seite: 2 / 4

Ama-Drainer A 522 ND/11

Versions-Nr.: 1

Positionsnr	Menge	Bezeichnung																																																																								
1800	1	<p>Ama-Drainer A 522 ND/11 Tauchmotorpumpe Z-53.3-423 VDE-GS laufradseitig: Siliziumkarbid-Balgleitringdichtung motorseitig: Wellendichtring und wartungsfreie Ölkammer mit umweltfreundlichem Paraffin öl Voll überflutbare transportabel oder stationär einsetzbare Tauchmotorpumpe, offenes Mehrschaufelrad, horizontaler Druckstutzen (vertikaler beiliegend), Drehstrommotor, Schutzart IP 68, thermischer Motorschutz, elektrische Anschlussleitung 10 m lang mit freiem Kabelende, ohne Stecker (die 2 herausgeführten potentialfreien Kontakte des thermischen Motorschutzes sind auch für Anzeige und Leittechnik geeignet). Ausführung ohne Schwimmerschalter.</p> <table border="0"> <tr> <td>Pumpentyp</td> <td>AmaDrainer</td> </tr> <tr> <td>Fördermedium</td> <td>Wasser, sauberes Wasser</td> </tr> <tr> <td>Max. Mediumtemperatur</td> <td>20,0 °C</td> </tr> <tr> <td>Temperaturgrenzen für gewählte</td> <td>40,0 °C</td> </tr> <tr> <td>Werkstoffausführung max.</td> <td></td> </tr> <tr> <td>Fördermenge</td> <td>35,10 m³/h</td> </tr> <tr> <td>Förderhöhe</td> <td>10,30 m</td> </tr> <tr> <td>Dichte</td> <td>998 kg/m³</td> </tr> <tr> <td>Viskosität</td> <td>1,00 mm²/s</td> </tr> <tr> <td>freier Durchgang bis</td> <td>11,0 mm</td> </tr> <tr> <td>Druckstutzen Nenndruck</td> <td>PN 6</td> </tr> <tr> <td>Zulauf Nennweite</td> <td>ohne</td> </tr> <tr> <td>Nennweite druckseitig</td> <td>G 2</td> </tr> <tr> <td>Betriebsspannung</td> <td>400 V</td> </tr> <tr> <td>Frequenz</td> <td>50 Hz</td> </tr> <tr> <td>elektr. Anschlussleistung P1</td> <td>2,90 kW</td> </tr> <tr> <td>Nennstrom max.</td> <td>4,8 A</td> </tr> <tr> <td>Drehzahl</td> <td>2800 1/min</td> </tr> <tr> <td>Motorfuß</td> <td>180 Grad</td> </tr> <tr> <td>Kühlmantel</td> <td>ohne</td> </tr> <tr> <td>Werkstoffvariante</td> <td>A</td> </tr> <tr> <td>Pumpengehäuse (101)</td> <td>Grauguss JL1040</td> </tr> <tr> <td>Werkstoff</td> <td></td> </tr> <tr> <td>Saugdeckel (162) Werkstoff</td> <td>Grauguss JL1040</td> </tr> <tr> <td>Pumpenstützfuss (182)</td> <td>Polyethylen (HDPE)</td> </tr> <tr> <td>Werkstoff</td> <td></td> </tr> <tr> <td>Welle (210) Werkstoff</td> <td>Chrom-Stahl 1.4021+QT800</td> </tr> <tr> <td>Laufrad (230) Werkstoff</td> <td>POLYAMID (PA)</td> </tr> <tr> <td>Statormantel (81-78)</td> <td>CrNi-Stahl 1.4301</td> </tr> <tr> <td>Werkstoff</td> <td></td> </tr> <tr> <td>Wellendichtungsart</td> <td>Einfachwirkende GLRD</td> </tr> <tr> <td>Wellendichtungshersteller</td> <td>KSB</td> </tr> <tr> <td>Wellendichtungshersteller typ</td> <td>MSA</td> </tr> <tr> <td>Wellendichtungs Material</td> <td>SIC/SIC/NBR</td> </tr> <tr> <td>Wellendichtungsart</td> <td>PM Gleitringdichtring</td> </tr> </table>	Pumpentyp	AmaDrainer	Fördermedium	Wasser, sauberes Wasser	Max. Mediumtemperatur	20,0 °C	Temperaturgrenzen für gewählte	40,0 °C	Werkstoffausführung max.		Fördermenge	35,10 m³/h	Förderhöhe	10,30 m	Dichte	998 kg/m³	Viskosität	1,00 mm²/s	freier Durchgang bis	11,0 mm	Druckstutzen Nenndruck	PN 6	Zulauf Nennweite	ohne	Nennweite druckseitig	G 2	Betriebsspannung	400 V	Frequenz	50 Hz	elektr. Anschlussleistung P1	2,90 kW	Nennstrom max.	4,8 A	Drehzahl	2800 1/min	Motorfuß	180 Grad	Kühlmantel	ohne	Werkstoffvariante	A	Pumpengehäuse (101)	Grauguss JL1040	Werkstoff		Saugdeckel (162) Werkstoff	Grauguss JL1040	Pumpenstützfuss (182)	Polyethylen (HDPE)	Werkstoff		Welle (210) Werkstoff	Chrom-Stahl 1.4021+QT800	Laufrad (230) Werkstoff	POLYAMID (PA)	Statormantel (81-78)	CrNi-Stahl 1.4301	Werkstoff		Wellendichtungsart	Einfachwirkende GLRD	Wellendichtungshersteller	KSB	Wellendichtungshersteller typ	MSA	Wellendichtungs Material	SIC/SIC/NBR	Wellendichtungsart	PM Gleitringdichtring		
Pumpentyp	AmaDrainer																																																																									
Fördermedium	Wasser, sauberes Wasser																																																																									
Max. Mediumtemperatur	20,0 °C																																																																									
Temperaturgrenzen für gewählte	40,0 °C																																																																									
Werkstoffausführung max.																																																																										
Fördermenge	35,10 m³/h																																																																									
Förderhöhe	10,30 m																																																																									
Dichte	998 kg/m³																																																																									
Viskosität	1,00 mm²/s																																																																									
freier Durchgang bis	11,0 mm																																																																									
Druckstutzen Nenndruck	PN 6																																																																									
Zulauf Nennweite	ohne																																																																									
Nennweite druckseitig	G 2																																																																									
Betriebsspannung	400 V																																																																									
Frequenz	50 Hz																																																																									
elektr. Anschlussleistung P1	2,90 kW																																																																									
Nennstrom max.	4,8 A																																																																									
Drehzahl	2800 1/min																																																																									
Motorfuß	180 Grad																																																																									
Kühlmantel	ohne																																																																									
Werkstoffvariante	A																																																																									
Pumpengehäuse (101)	Grauguss JL1040																																																																									
Werkstoff																																																																										
Saugdeckel (162) Werkstoff	Grauguss JL1040																																																																									
Pumpenstützfuss (182)	Polyethylen (HDPE)																																																																									
Werkstoff																																																																										
Welle (210) Werkstoff	Chrom-Stahl 1.4021+QT800																																																																									
Laufrad (230) Werkstoff	POLYAMID (PA)																																																																									
Statormantel (81-78)	CrNi-Stahl 1.4301																																																																									
Werkstoff																																																																										
Wellendichtungsart	Einfachwirkende GLRD																																																																									
Wellendichtungshersteller	KSB																																																																									
Wellendichtungshersteller typ	MSA																																																																									
Wellendichtungs Material	SIC/SIC/NBR																																																																									
Wellendichtungsart	PM Gleitringdichtring																																																																									

Ausschreibungstext



Kunden-Pos.-Nr.:
Bestell-Datum: 02.03.2011
Bestellnummer: Blitzangebot 2011-03-02
Menge: 1

Nummer:
Positionsnr.: 1800
Datum: 02.03.2011
Seite: 3 / 4

Ama-Drainer A 522 ND/11

Versions-Nr.: 1

Positionsnr	Menge	Bezeichnung		
		Dichtungseinbauraum Aufstellart Gewicht Hersteller	pumpenseitig Standard Dichtungsraum Vertikal 23 kg KSB	

Aufstellungsplan



Kunden-Pos.-Nr.:
Bestell-Datum: 02.03.2011
Bestellnummer: Blitzangebot 2011-03-02
Menge: 1

Nummer:
Positionsnr.: 1800
Datum: 02.03.2011
Seite: 4 / 4

Ama-Drainer A 522 ND/11

Versions-Nr.: 1

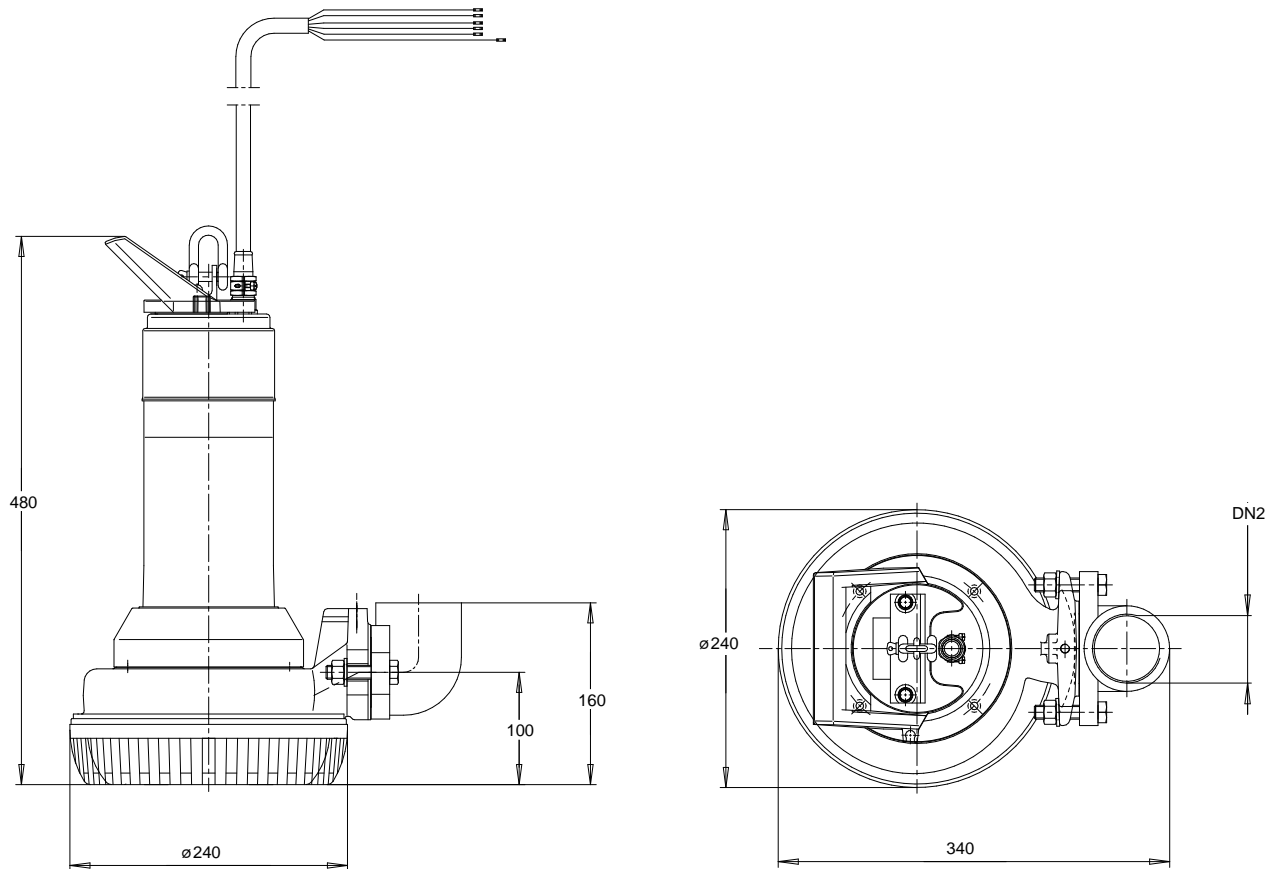

Darstellung ist nicht maßstäblich

Maße in mm

Motor

Motorfabrikat	KSB
Motorgröße	2,2
Leistung Motor	2,20 kW
Drehzahl	2800 1/min

Anschlüsse

Druckstutzen Nennweite	G 2 / EN ISO 228-1
DN2	
Nenndruck drucks.	PN 6
90°-Winkelstück mit Innengewinde G2 im Lieferumfang	

Gewicht netto

Pumpe	23 kg
Summe	23 kg

Leitungen spannungsfrei anschließen!